

Modular Gearless Machines

For high-rise elevators

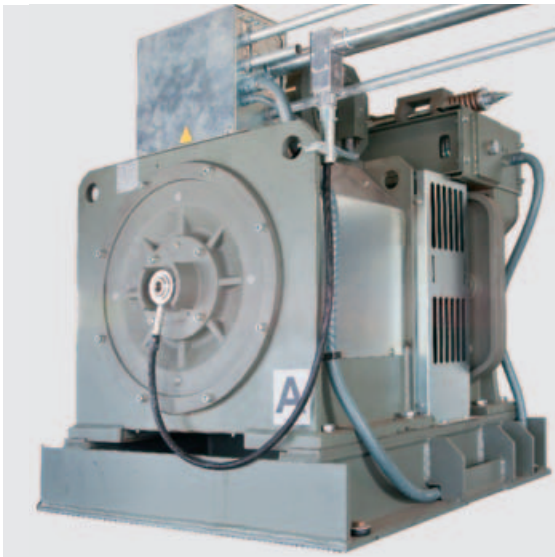
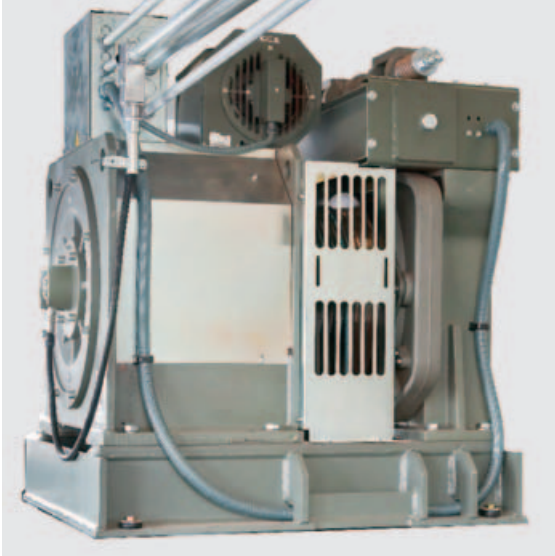

Schindler modular gearless machines are specifically designed to simplify installation in existing machine rooms, while maintaining optimized ride quality. They can be disassembled at the job site and then reassembled in the machine room.

Their compact design and minimum dimensions can normally fit through standard machine room doors. Dimensions are optimized so that they are compatible with corresponding hoistway dimensions.

The machines are factory tested and delivered fully assembled to the job site, including the machine frame and leveling units, reducing installation time. The secondary sheave is delivered separately.

KT
Kits

AC
Accessories

CW
Counter-weights

SA
Safeties

FI
Fixtures

CA
Cars

DO
Doors

MM
Mechanical material

CO
Controls

DR
Drives



Modular Gearless Machines

For high-rise elevators

Dimensions

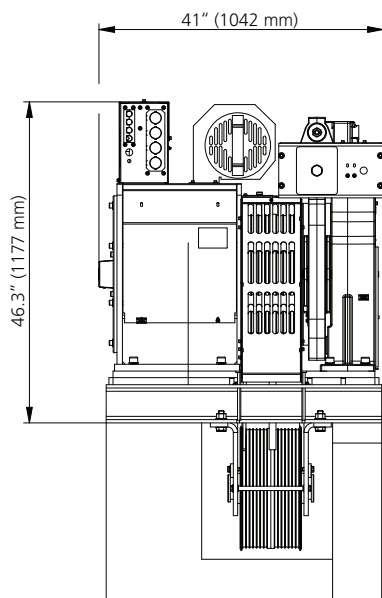
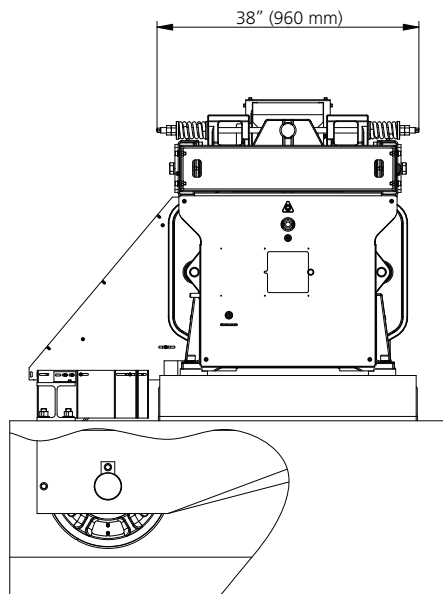

Characteristics

FMR 355 gearless machine: AC motor technology

Weight with secondary sheave	4100 lbs. (1'860 kg)
Weight without secondary sheave	3527 lbs. (1'600 kg)
Number of starts per hour	240
Degree of protection	IP21
Rated motor output	max. 53 kW
Rated voltage of motor	340 / 460 V
Frequency	50 / 60 Hz
Height to center line of motor shaft	14.2" (355 mm)
Traction sheave	
– Wrapping	double
– Diameter	17" (440 mm)
– Width	9" (225 mm)
Diameter of suspension ropes	7/16" (11 mm)
Distance of rope falls	31.5" – 50" (800 mm – 1275 mm)
Number of ropes	max. 8
Number of rope grooves	16
Roping	2:1
Shape of grooves	Semicircular

PMR 355 gearless machine: Permanent magnet technology

Weight with secondary sheave	4500 lbs. (2'040 kg)
Weight without secondary sheave	3924 lbs. (1'780 kg)
Number of starts per hour	240
Degree of protection	IP21
Rated motor output	max. 53 kW
Rated voltage of motor	340 / 460 V
Frequency	50 / 60 Hz
Height to center line of motor shaft	14" (355 mm)
Traction sheave	
– Wrapping	double
– Diameter	17" (440 mm)
– Width	9" (225 mm)
Diameter of suspension ropes	7/16" (11 mm)
Distance of rope falls	31.5" – 50" (800 mm – 1275 mm)
Number of ropes	max. 8
Number of rope grooves	16
Roping	2:1
Shape of grooves	Semicircular

For further information including location of the Schindler office nearest you, please visit:

www.us.schindler.com

North American Headquarters
Morristown, New Jersey 07962-1935
Tel. 973.397.6500



Schindler is a member organization of the U.S. Green Building Council.



Schindler has received renewal to ISO 14001:2004 and ISO 9001:2000 certificates.

ISO 9001 - ISO 14001



Schindler prints with vegetable-based ink on paper containing post-consumer waste fiber.



Mixed Sources
Product group from well-managed forests, controlled sources and recycled wood or fiber.
www.fsc.org Cert no. SCS-COC-00547
©1996 Forest Stewardship Council