

Hydraulic Elevator Jack Replacement

Get safe operation, avoid downtime and environmental remediation

If your building has hydraulic elevators with traditional, underground jacks that are not protected with safety bulkheads and PVC liners, Schindler has a solution to help mitigate your current risk of:

- Costly remediation due to oil pollution
- Extended downtime due to equipment failure
- Unplanned, unbudgeted expenditures
- Passenger safety risk from rapid oil loss.

Why hydraulic jacks fail

Older hydraulic elevators are propelled by a jack encased in a cylinder and buried in the ground beneath the elevator. The problems with these older designs include:

- Direct contact with soil, ground water and air and therefore constantly subjected to corrosive conditions
- Welds attaching the single bottom disc to the cylinder are prone to failure and leaks.

Are you at risk?

By the late 1990s, it became industry standard for a below ground cylinder to be encased in a PVC liner. If your elevator was installed prior to this time and it has not had a cylinder replacement, you may be at risk.

The consequences of a jack failure include:

- Hydraulic fluid seeping into the soil and ground water requiring costly environmental remediation work
- Immediate, code-mandated removal of the jack
- Up to 10 weeks for an unplanned jack replacement.

Schindler's proactive solution

You may not have a problem now but there is no reliable way to visually inspect the jack to determine whether corrosion has compromised its integrity. One thing that can be done is to test your jack system by performing a full load static test (loading the elevator to its rated load) and to monitor the system for oil loss.

Unfortunately, some cylinders do not develop gradual leaks but rather fail suddenly and catastrophically, with no prior indications of any problems. It all depends on the complex and varying underground soil and water conditions.

If your elevators were installed prior to the late 1990s and you are unsure if their cylinders have been replaced, Schindler recommends proactively replacing your older hydraulic jack assembly with a modern double bottom system that is encased in PVC, and which incorporates a moisture monitoring system. This proactive approach will:

- Substantially extend the life of your elevator
- Reduce unplanned service interruptions
- Dramatically reduce jack replacement time
- Protect against costly environmental remediation.



Photo shows where failure occurred due to corrosion that deteriorated the cylinder at or near the bottom welds.

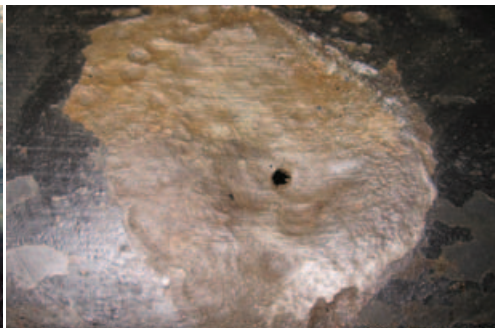

Photo shows how corrosion can compromised the wall of the unprotected cylinder eventually leading to a leak.



Hydraulic Elevator Jack Replacement

Get safe operation, avoid downtime and environmental remediation

Complete jack replacement process

In the simplest scenario, a jack replacement involves:

- Securing the elevator car high in the hoistway
- Unfastening the jack assembly from the car and the hydraulic fittings
- Removing the entire jack assembly
- Inserted the new jack into the original jackhole
- Adjusted and secured
- Re-attached to the car and fittings.

Because soil conditions are unpredictable, in some cases the old hole may partially fill with soil when the old jack is removed. If that happens, or if the new jack has a larger diameter due to a corrosion-resistant lining, re-drilling and possibly other jackhole work will be needed to prepare the hole for the new jack.

Take the next step

Schindler can help you evaluate your current situation and formulate a plan of action that will help make your existing hydraulic elevators safe, reliable and fully code compliant. In many cases we can offer you a financing plan to spread payments for this work over time. Please contact your Schindler representative to arrange an appointment to review your installation and begin this essential jack replacement process.

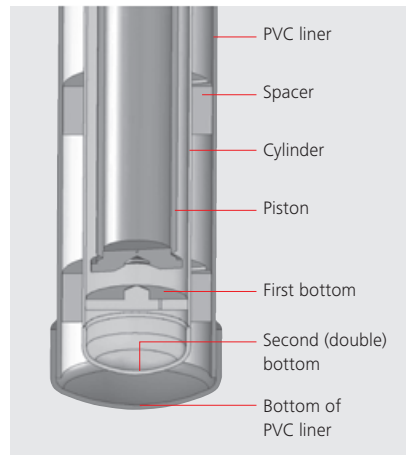

A typical Schindler replacement jack features the double bottom and PVC liner. Together they provide the best available protection against jack failure.

U.S. Headquarters. Morristown, New Jersey

Tel. 973.397.6500

www.us.schindler.com

Canada Headquarters. Toronto, Ontario

Tel. 416.332.8280

www.ca.schindler.com



Schindler is a member organization of the U.S. Green Building Council.



Schindler has received renewal to ISO 9001 and ISO 14001 certificates.



Schindler prints with vegetable-based ink on paper containing post-consumer waste fiber.