

Schindler 3300 XL MRL Traction Elevator

Entrance details

Single-speed center opening (SSCO) side jamb

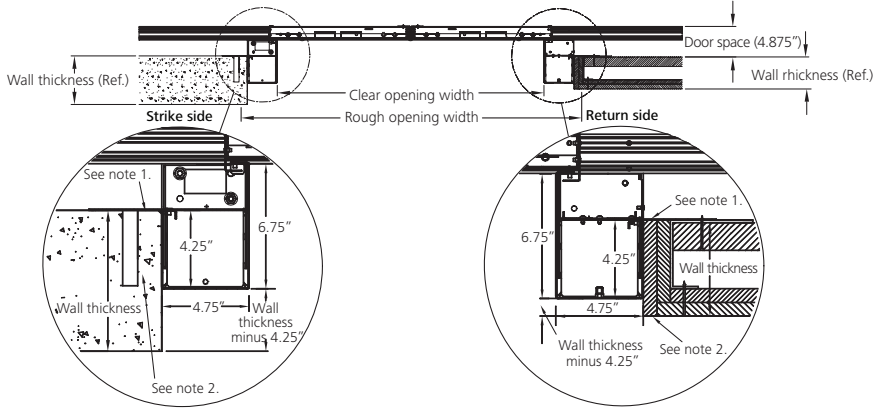

Single-speed center opening (SSCO) top jamb

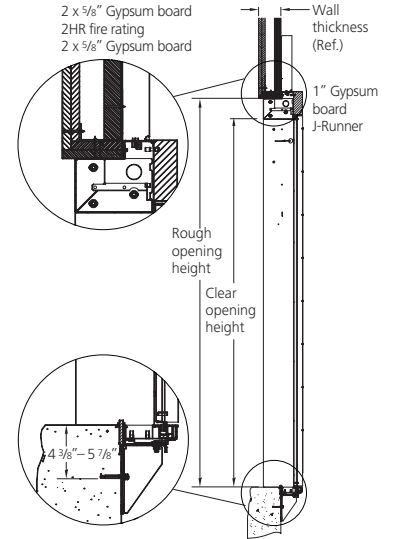

Two-speed side opening (2SSO) side jamb

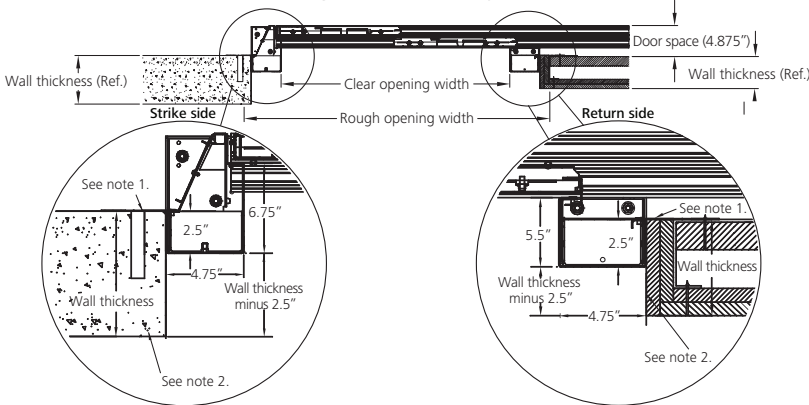

Two-speed side opening (2SSO) top jamb

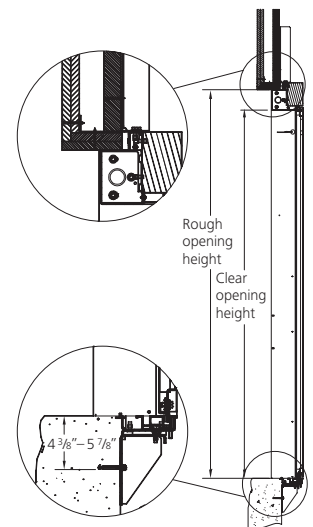

Dimensions

| Capacity lbs (kg) | Door Type | Clear Opening Width x Height ft (mm) | Rough Opening Width x Height ft (mm) |
|-------------------|-----------|--------------------------------------|--------------------------------------|
| 3500 (1590) | 2SSO | 3'-6" x 7'-0" (1067 x 2134) | 4'-10" x 7'-8" (1473 x 2337) |
| | SSCO | 3'-6" x 7'-0" (1067 x 2134) | 4'-10" x 7'-8" (1473 x 2337) |
| 4000 GP (1816) | SSCO | 4'-0" x 7'-0" (1219 x 2134) | 5'-4" x 7'-8" (1626 x 2337) |
| | SSCO | 4'-0" x 8'-0" (1219 x 2439) | 5'-4" x 8'-8" (1626 x 2642) |
| | SSCO | 4'-0" x 9'-0" (1219 x 2743) | 5'-4" x 9'-8" (1626 x 2947) |
| 4000 HS (1816) | 2SSO | 4'-0" x 7'-0" (1219 x 2134) | 5'-4" x 7'-8" (1626 x 2337) |
| | 2SSO | 4'-0" x 8'-0" (1219 x 2439) | 5'-4" x 8'-8" (1626 x 2642) |
| | 2SSO | 4'-0" x 9'-0" (1219 x 2473) | 5'-4" x 9'-8" (1626 x 2947) |
| 4500 HS (2043) | 2SSO | 4'-0" x 7'-0" (1219 x 2134) | 5'-4" x 7'-8" (1626 x 2337) |
| | 2SSO | 4'-0" x 8'-0" (1219 x 2439) | 5'-4" x 8'-8" (1626 x 2642) |
| | 2SSO | 4'-0" x 9'-0" (1219 x 2473) | 5'-4" x 9'-8" (1626 x 2947) |
| 5000 HS (2270) | 2SSO | 4'-0" x 7'-0" (1219 x 2134) | 5'-4" x 7'-8" (1626 x 2337) |
| | 2SSO | 4'-0" x 8'-0" (1219 x 2439) | 5'-4" x 8'-8" (1626 x 2642) |
| | 2SSO | 4'-0" x 9'-0" (1219 x 2473) | 5'-4" x 9'-8" (1626 x 2947) |
| | 2SSO | 4'-6" x 7'-0" (1372 x 2134) | 5'-10" x 7'-8" (1778 x 2337) |
| | 2SSO | 4'-6" x 8'-0" (1372 x 2439) | 5'-10" x 8'-8" (1778 x 2642) |
| | 2SSO | 4'-6" x 9'-0" (1372 x 2473) | 5'-10" x 9'-8" (1778 x 2947) |

Notes:

1. Fire rating is maintained by the interface at this area only.
2. Finished wall by others. No fire rating at this point. Wall thickness can vary, as jamb thickness remains constant.
3. LDU, or Landing Door Unit, provides access to the test and inspection panel, used during inspection or maintenance of the elevator.
4. Rough opening height for an LDU floor at 3,500 lbs., depending on configuration, and greater capacities, require door height plus 16" at LDU jamb.



Schindler

Schindler 3300 XL MRL Traction Elevator

Entrance details

Landing door mounting options

Landing doors

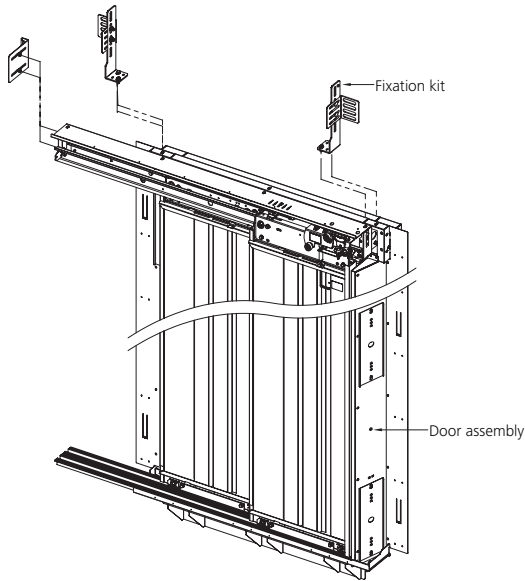

Landing door overview

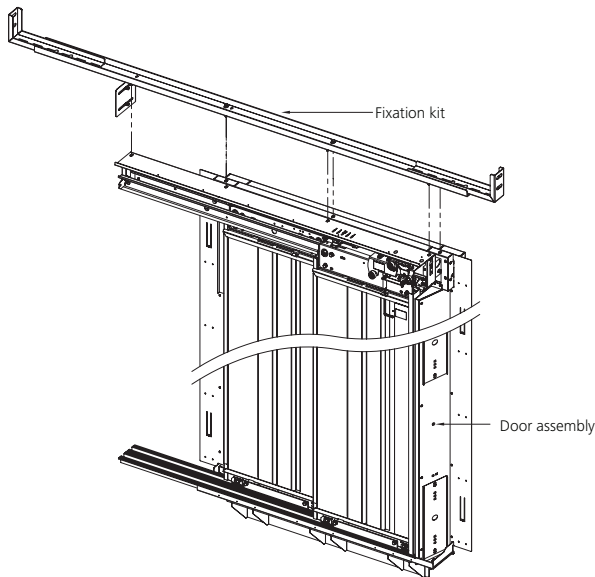

General requirements

Requirements for installation vary by type of equipment selected. These general requirements will serve as a guide to assist you in preparing your building for the installation of Schindler elevators. All designs, clearances, construction, workmanship and materials, unless specifically excepted, shall be in accordance with the requirements of the latest published ASME A17.1 Code for electric traction elevators (refer to Part 2) plus applicable building code and local codes. State or local requirements must be used if more stringent.

Items to be provided — To complete the installation, the following items must be considered, which are not included in the elevator contract:

Entrances

1. Hoistway walls are to have a fire-resistance rating, per ASME A17.1 Rule 2.1.1.1.
2. Furnishing, installing and maintaining the required fire rating of elevator hoistway walls, including the control spaces and also the penetration of fire wall by elevator fixture boxes (if applicable), is not the responsibility of the elevator contractor.
3. The interface of the elevator wall with the hoistway entrance assembly shall be in strict compliance with the elevator contractor's requirements.
4. Entrance wall and finished floor are not to be constructed until after door frames and sills are in place. All sill supports must be in place prior to material delivery.
 - a. Where front walls are reinforced concrete, concrete openings must be minimum 16" (406 mm) wider [8" (203 mm) on each side] and 8" (203 mm) higher than the clear opening.
 - b. Where drywall or sheet rock construction is used for front walls, it shall be of sufficient strength to maintain the doors in true lateral alignment. Drywall contractor to coordinate with the elevator contractor.
 - c. Door frames are to be anchored to walls and properly grouted in place to maintain legal fire rating (masonry construction).
5. Filling and grouting around entrance by others.
6. Where openings occur, all walls must be plumb, and sill supports must be level and flush with hoistway walls.

Approvals

Project _____
 Location _____
 Contract # _____
 Approved _____
 Date _____

Schindler 3300 XL entrance frame and door finish

#4 Brushed stainless steel at floors _____
 Powder coated (color) _____
 at floors _____

Schindler 3300 XL door opening front

Left-hand Right-hand Center

Schindler 3300 XL door opening rear

Left-hand Right-hand Center.

U.S. Headquarters. Morristown, New Jersey
 Toll-Free 877.696.8382
www.us.schindler.com

Canada Headquarters. Scarborough, Ontario
 Tel. 416.332.8280
www.ca.schindler.com



Schindler is a member organization of the U.S. Green Building Council.



Schindler has received renewal to ISO 14001:2004 and ISO 9001:2008 certificates.



Schindler prints with vegetable-based ink on paper containing post-consumer waste fiber.

